

# Installation Instructions for ASHCROFT® 8008 Pressure Gauge



## Applicable Standards:

- EN 837-1 Bourdon tube pressure gauges, dimensions, metrology, requirements and testing.
- EN 837-2 Selection and installation recommendations for pressure gauges.
- ASME B40.100 Pressure gauges and gauge attachments
- 2014/68/EC Pressure equipment directive.

**Specifications:** Refer to Ashcroft Type 8008 data sheet (Ash Bul HG-1) at [www.ashcroft.com](http://www.ashcroft.com)

## 1. SAFETY



Before installation, be certain the appropriate gauge has been selected considering operating pressure/full scale pressure/proof pressure, wetted material requirements, media compatibility, operating temperature, vibration, pulsation, desired accuracy and any other gauge component related to the service application (including the potential need for protective attachments and/or special installation requirements). Failure to do so could result in equipment damage, gauge failure and/or personal injury. Only qualified personnel should be permitted to install and maintain pressure gauges.

## 2. INSTALLATION

When installing the gauge connection into the application, use the wrench area (above the threaded portion) to thread in and tighten the gauge. Do not use the gauge case to install the gauge. This could result in loss of accuracy, excessive friction, or mechanical damage to the pressure element or gauge case.

The gauge connection must be compatible with the mating connection and must be assembled appropriately. If the mating parts do not seal completely, a sealing material may be considered.

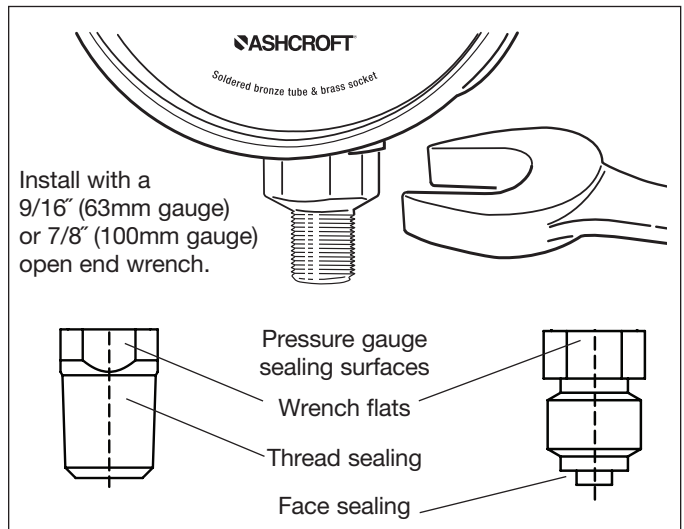

After installation, pull up the blue cap on the fill/vent plug to the full open position. Opening the vent plug will relieve internal pressure changes in the gauge case that otherwise would have been induced by environmental changes in pressure and/or temperature. Without being vented this change in internal pressure could adversely affect the accuracy of the gauge. If liquid filled, only open vent plugs when the plug is oriented in the vertical position.

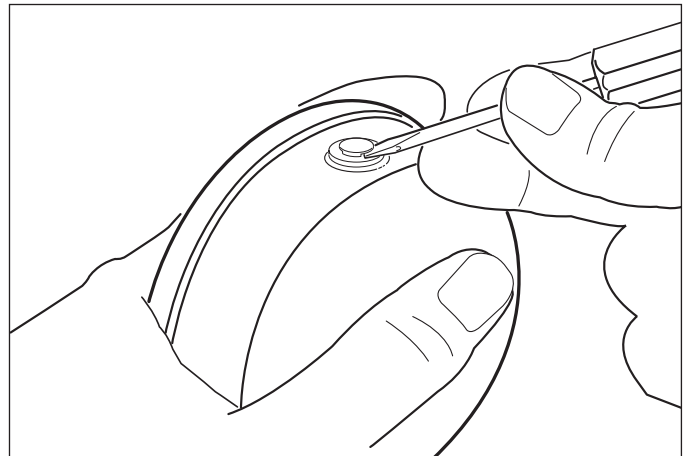

## 3. STORAGE

Gauge should remain in original packaging until installation. This will protect from mechanical damage as well as environmental conditions. Storage temperature range from -40 °F to 158 °F (-40 °C to 70 °C).

## 4. MAINTENANCE/REPAIRS

Check regularly to ensure the gauge is in good working order. When removing the gauge from the application make sure there is no pressure in the system and all system media has been isolated from the gauge. If gauge is damaged or out of calibration a new gauge must be installed.

**These gauges are not to be re-calibrated.**

Misuse or misapplication of this gauge could result in gauge failure, equipment damage and/or personal injury.

**Installation Instructions  
for ASHCROFT® 8008  
Pressure Gauge**



**5. FRONT FLANGE AND U-CLAMP MOUNTING**

**Installation Instructions for 8008 Front Flange Mounting Kit**

1. Align any screw hole with gauge fill plug and press flange onto back of case until it touches front ring. To prevent warping, press evenly around perimeter of flange as it forms around case.
2. Drill panel hole for gauge, and drill 3 clearance OR tapped holes (120° apart) for mounting screws (see table for sizes).
3. Use hardware provided to secure gauge to panel.

NOTE: Use an open end wrench on the gauge process connection when connecting gauge to pressure source.

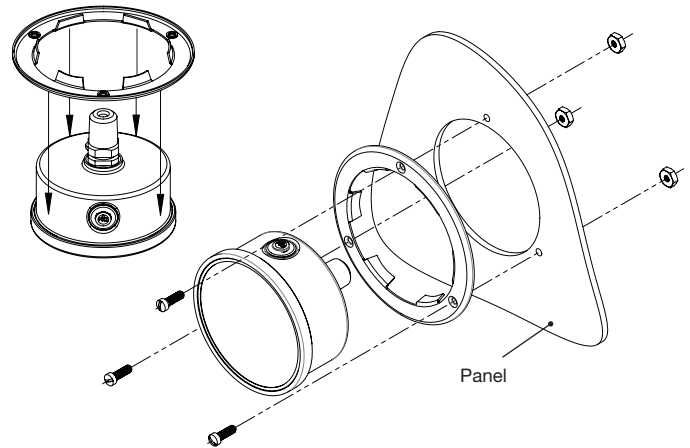

Gauge Size	Kit Part No.	Panel Hole		Bolt Circle	Screw	
		Min	Max		Clearance	Tap Hole/Thread Size
63mm	101A230-03	2.60" (66.0mm)	2.70" (68.8mm)	2.95" (75mm)	.150" (3.8mm)	.1065"/#6-32 UNC
100mm	101A230-04	4.06" (103.0mm)	4.15" (105.4mm)	4.65" (118mm)	.201" (5.1mm)	.159"/#10-32 UNF

**Installation Instructions Type 8008 U-Clamp Mounting Kit**

1. Drill panel hole for gauge (see table for sizes).
2. Place gauge through panel. Assemble bracket onto process connection using square keyway, then shift bracket to engage into groove of process connection.
3. Install screws (provided) through bracket and tighten onto panel until gauge is secure (5 - 7 in-lbs).

NOTE: Use an open end wrench on the gauge process connection when connecting gauge to pressure source.

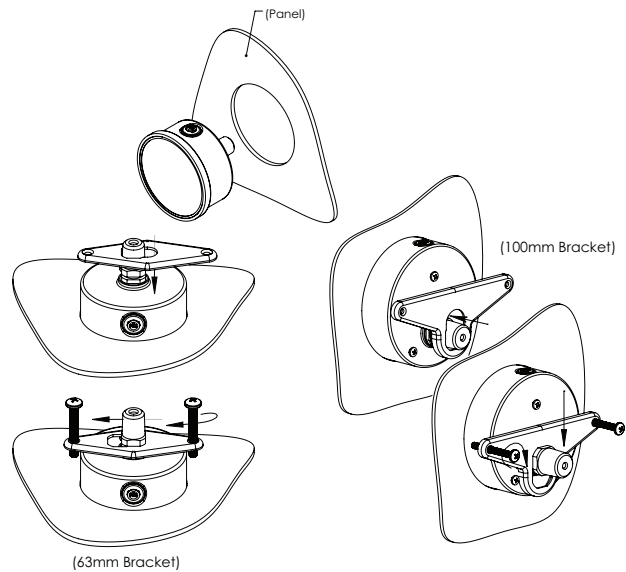

Gauge Size	Kit Part No.	Panel Hole	
		Min	Max
63mm	101A230-01	2.52" (64.0mm)	2.56" (65.0mm)
100mm	101A230-02	3.98" (101.0mm)	4.02" (102.0mm)