

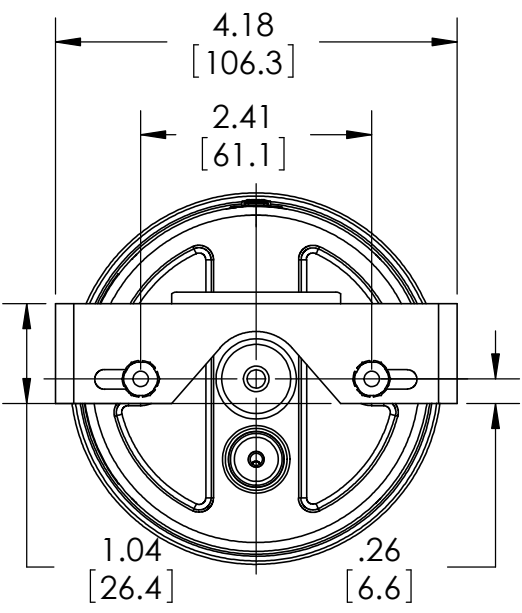

This drawing includes confidential information which is the property of ASHCROFT INC. This copy is loaned for a specific purpose, with the understanding that it will not be reproduced or used for any other purpose or disclosed to others, and it will be returned on demand.

NOTE 1: BRACKET POSITIONED FOR 1/4" PANEL
 NOTE 2: PANEL THICKNESS RANGES FROM 1/16" TO 1/4"
 NOTE 3: PANEL CUTOUT-3.66 [93] +/- .03[1]

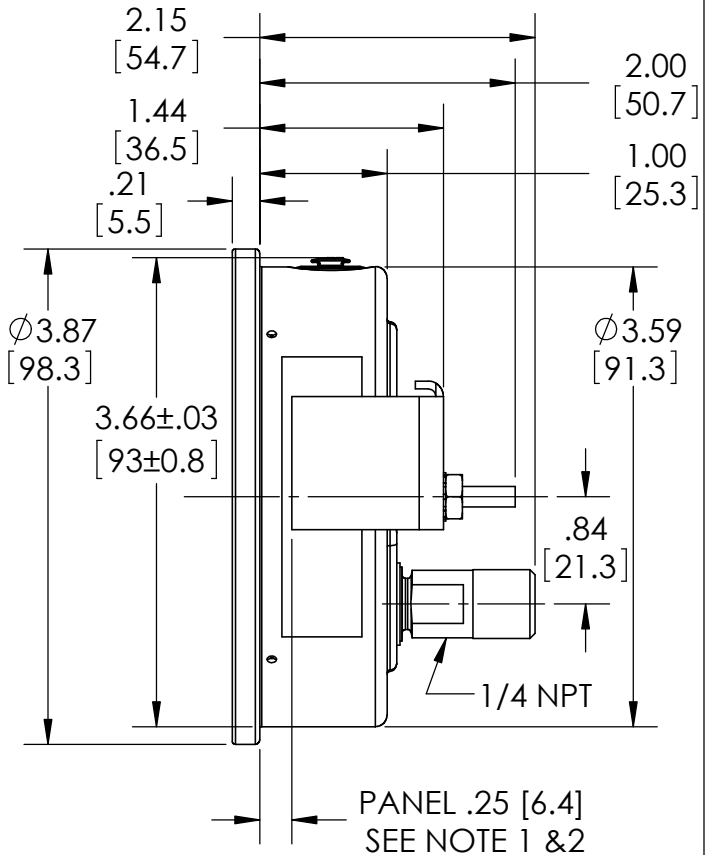
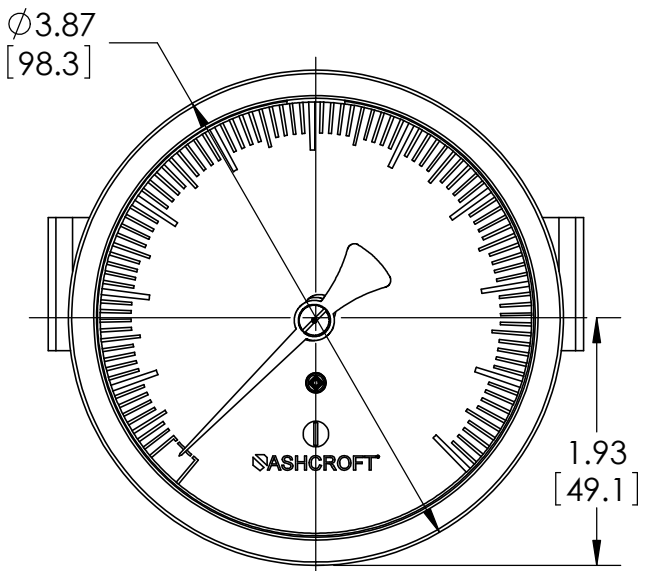

REAR VIEW

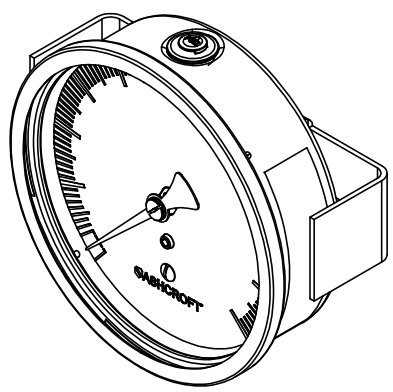

DIMENSIONS IN [] ARE MILLIMETERS

REV.	ECO	DESCRIPTION	BY	DATE
A	0004508	RELEASED GENERAL DIMS. FOR 10 1008S 02B XUC	MJS	6/23/2010

This print certified correct for		General Dimensions			
Customer's Name		10 1008S 02B XUC SERIES			
Customer's Order No.	Drawn MJS	Date 6/23/10	Date of Issue		
Ashcroft Order No.	Checked	Date	SHEET-1		Rev.
Certified by	Date	Approved	Date	70A3073	A